



2023 - 2024

PS1

Mon cahier d'activités pour les vacances

PS1



Le graphisme, premiers pas vers l'écriture

Observe attentivement puis continue comme sur le modèle.

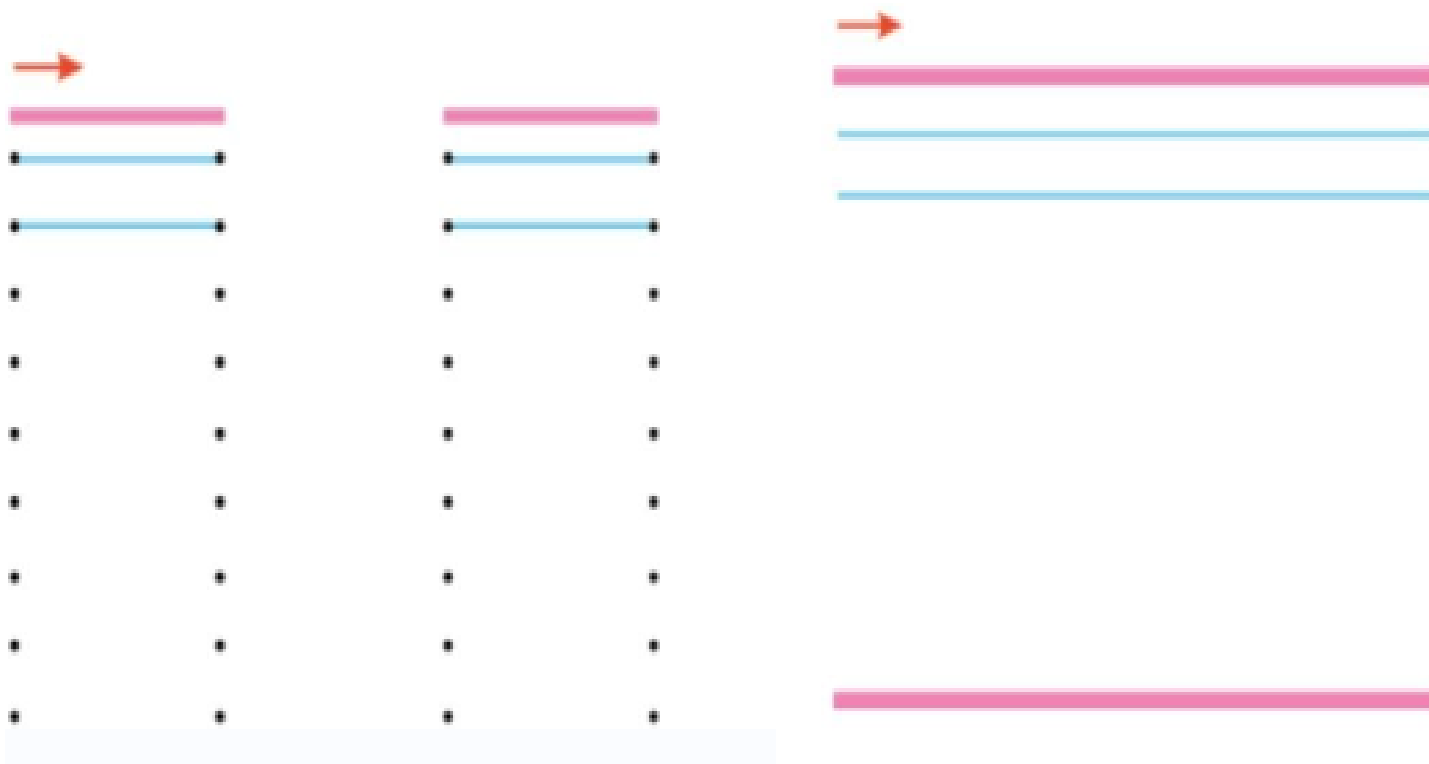

Trace la pluie qui tombe des nuages.



Dessine les rayons du soleil.

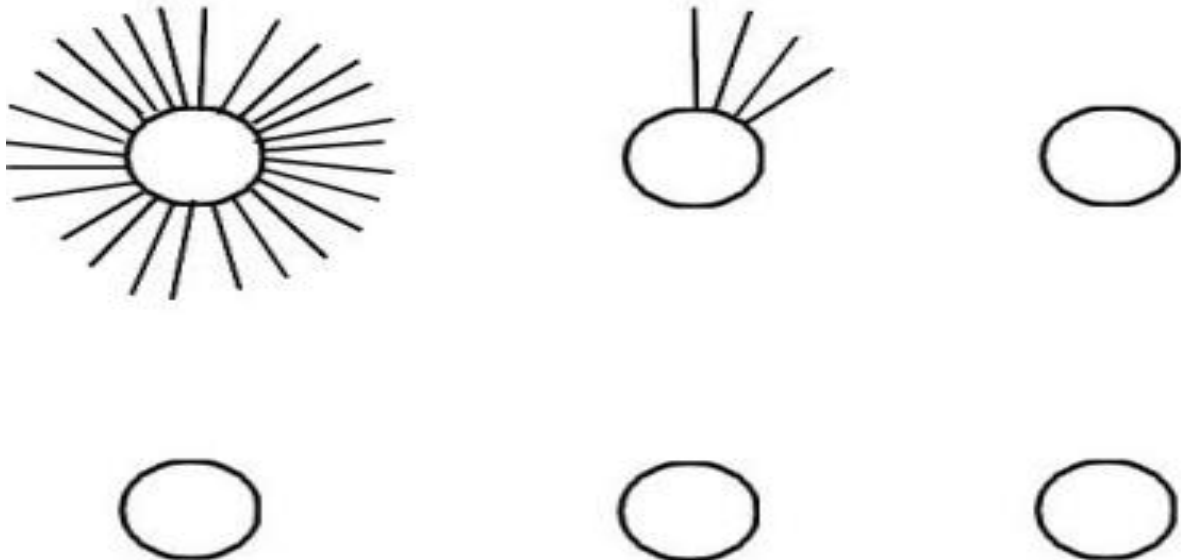

Entoure le chiffre 1 en rouge.

1

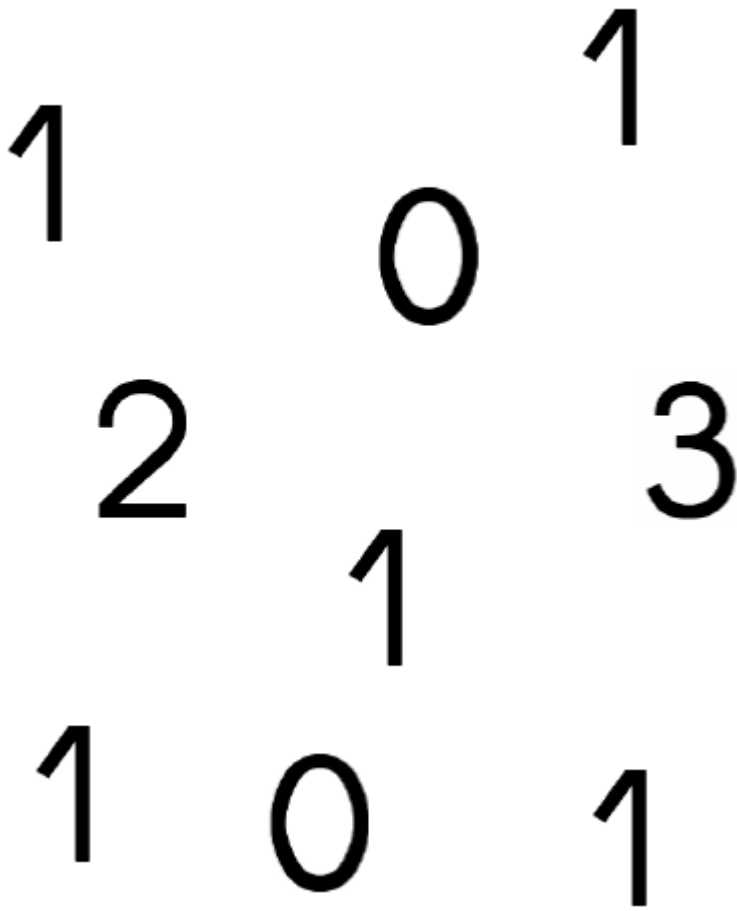

Retrace le chiffre 1.

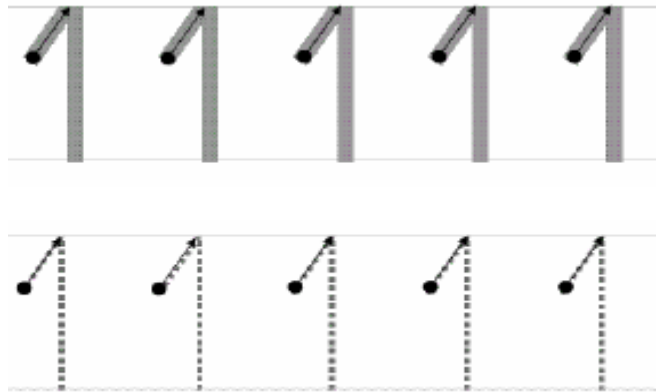

Colorie : sans dépasser, sans laisser de blanc.

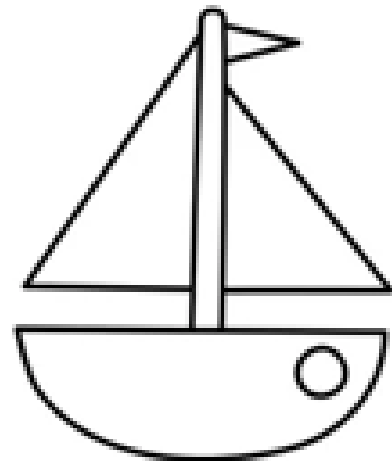
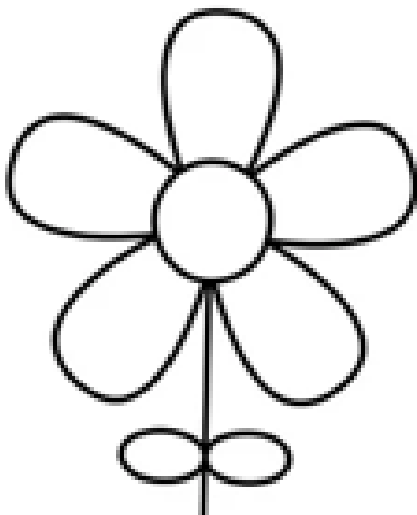

Dessine les vagues.

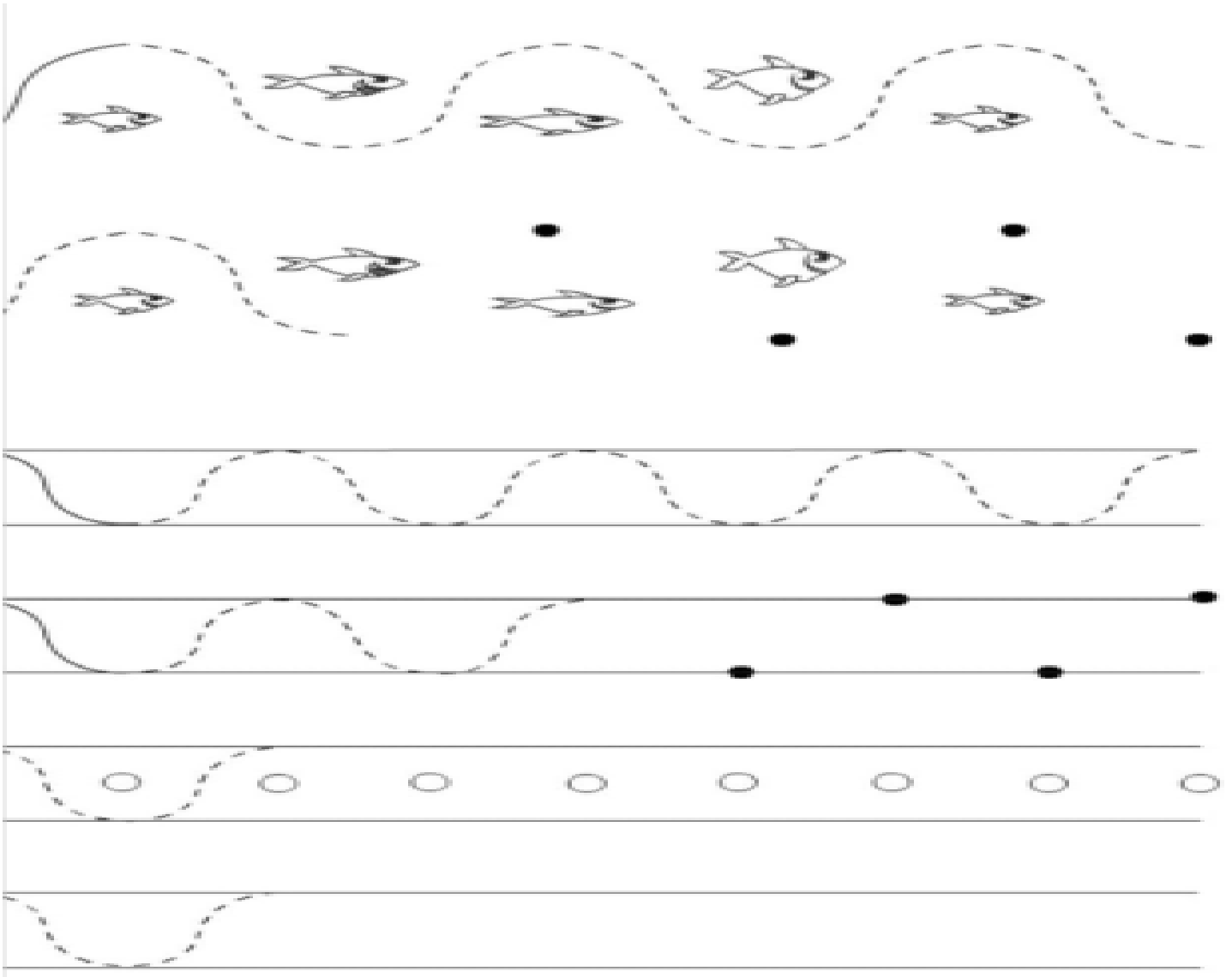

Trace la nage des poissons à l'intérieur du chemin.

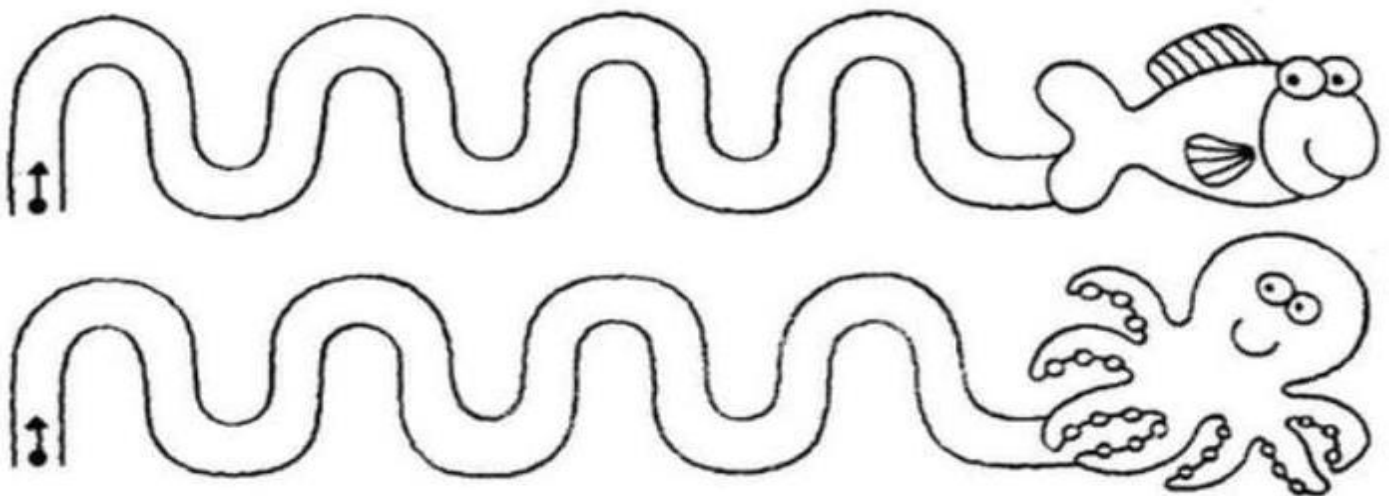

Regroupe les cloches par **2**.



Essaie d'écrire le chiffre **2**.

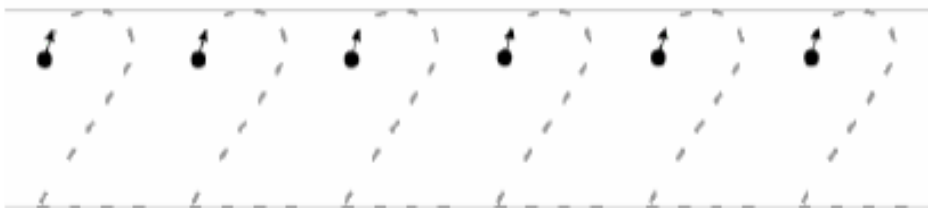

Colorie les pommes en rouge.

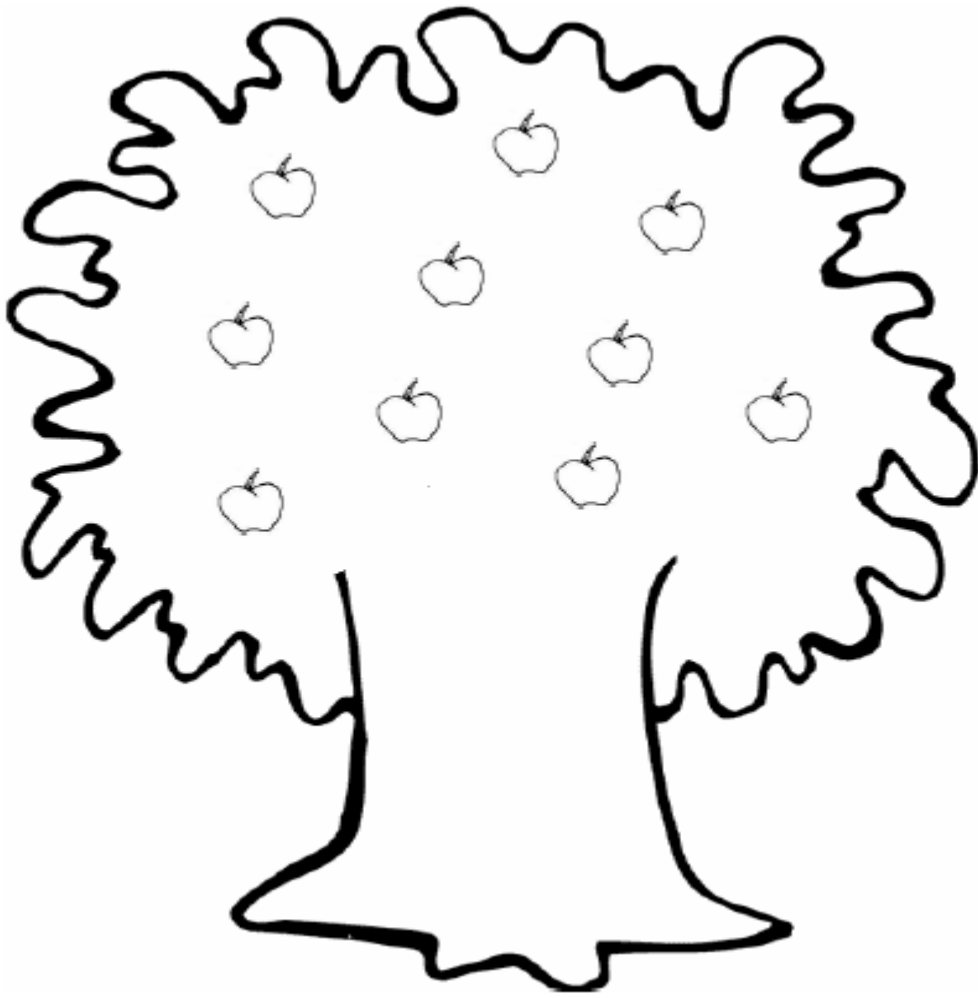

Relie les fleurs identiques.

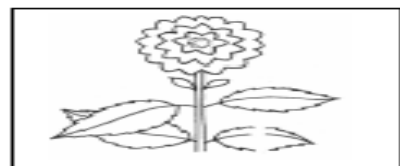
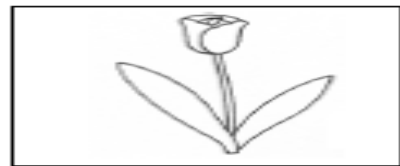
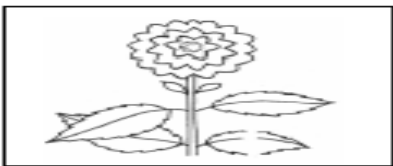
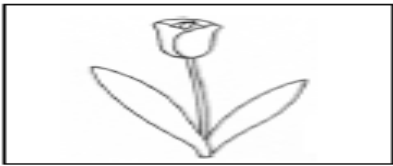

Trace des lignes brisés pour terminer les coquilles.



Fais des points rouges et noirs sur les chapeaux des champignons.



Repasse sur les lignes en pointillés pour dessiner des ronds. Suis la direction indiquée par la flèche.

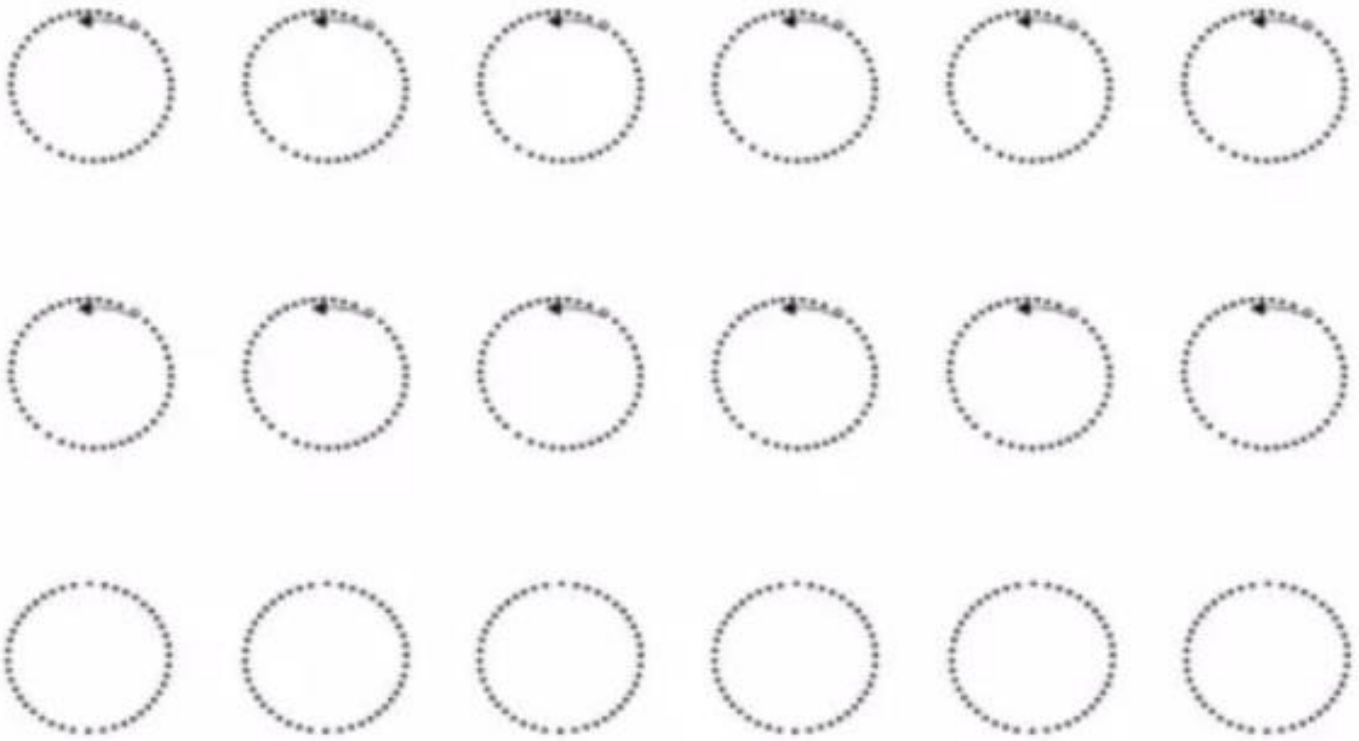

Compte les bougies puis relie.

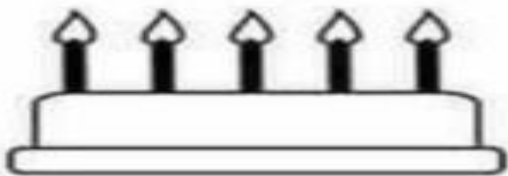
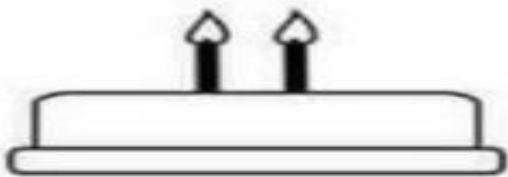
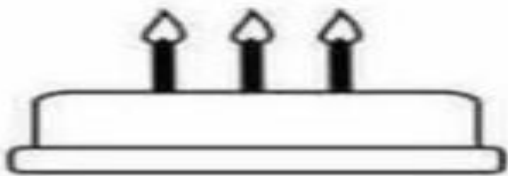
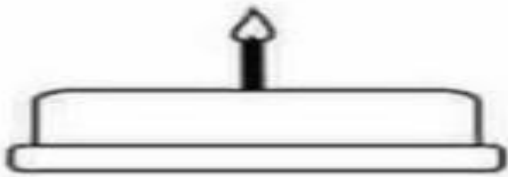
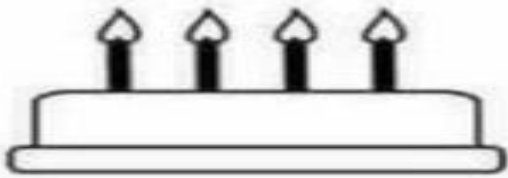

2

4

5

1

3

Observe et complète.

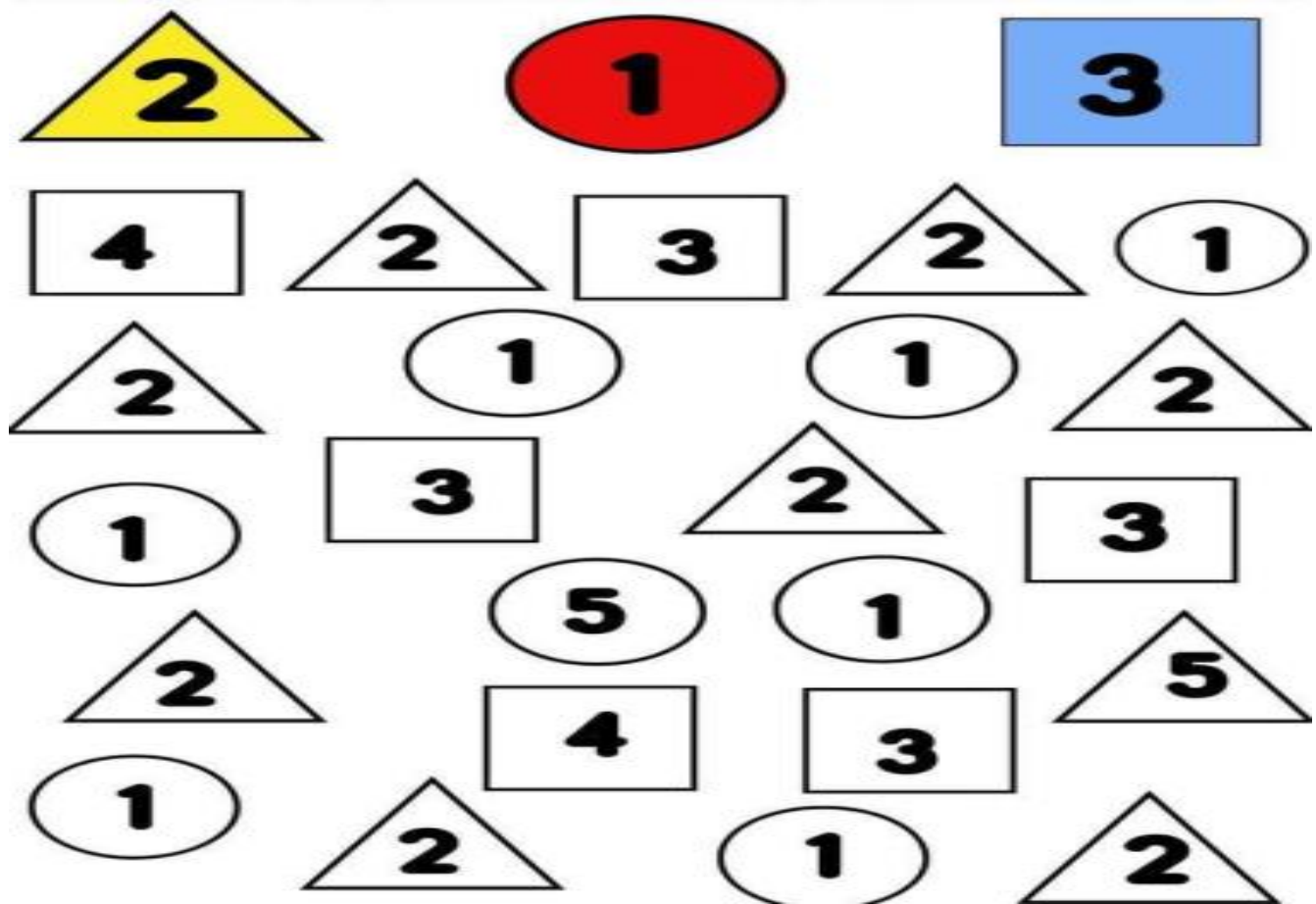

Continue le dessin des pétales de la fleur.

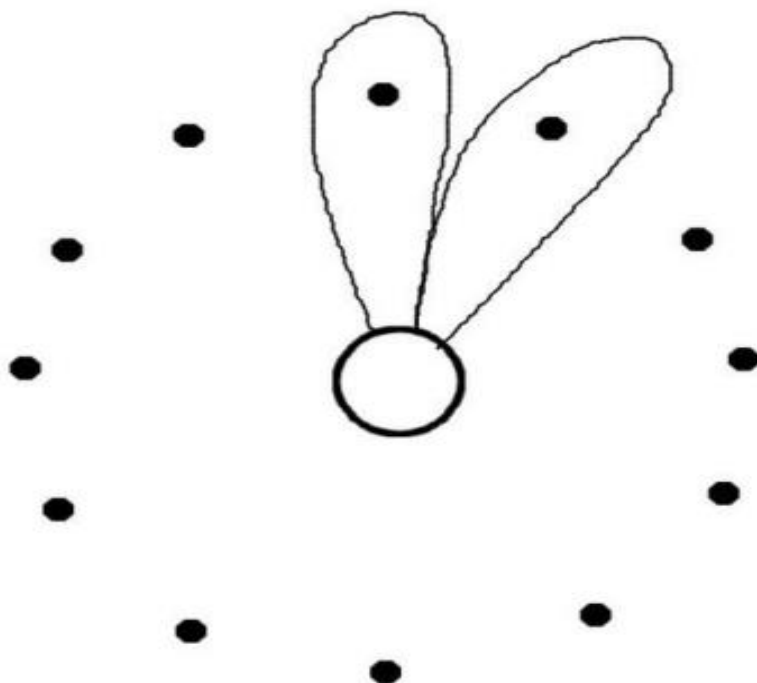

Colorie : sans dépasser, sans laisser de blanc.

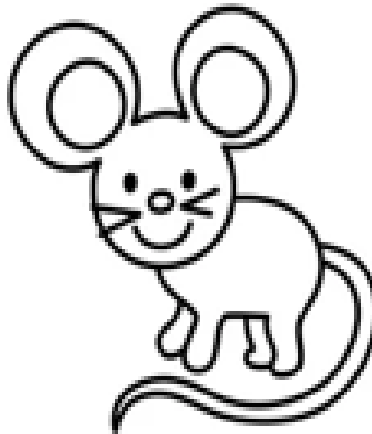

Essaie d'écrire le chiffre **3**.

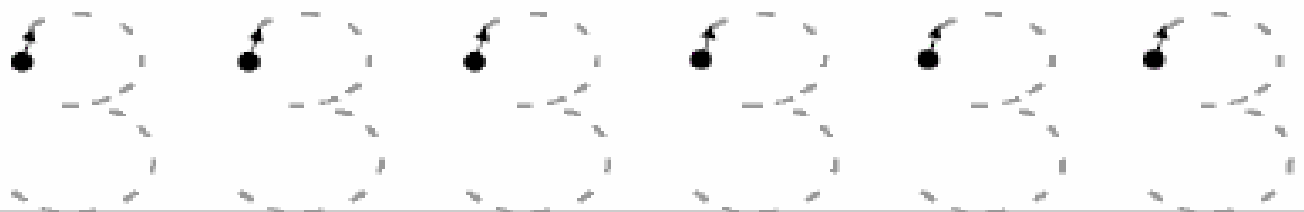
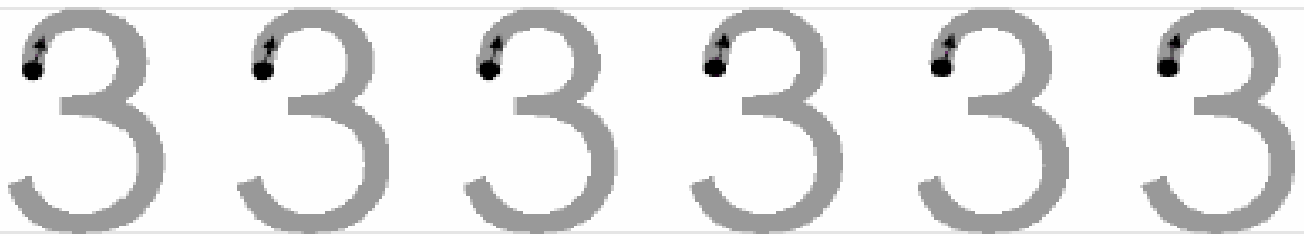

Regroupe les cœurs par **3**.

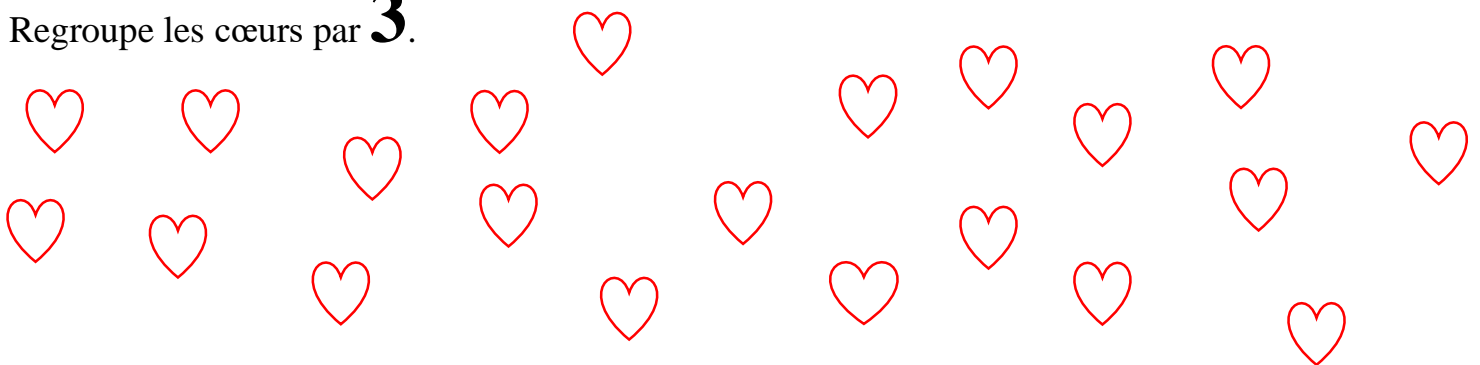

Termine le feston des biscuits.

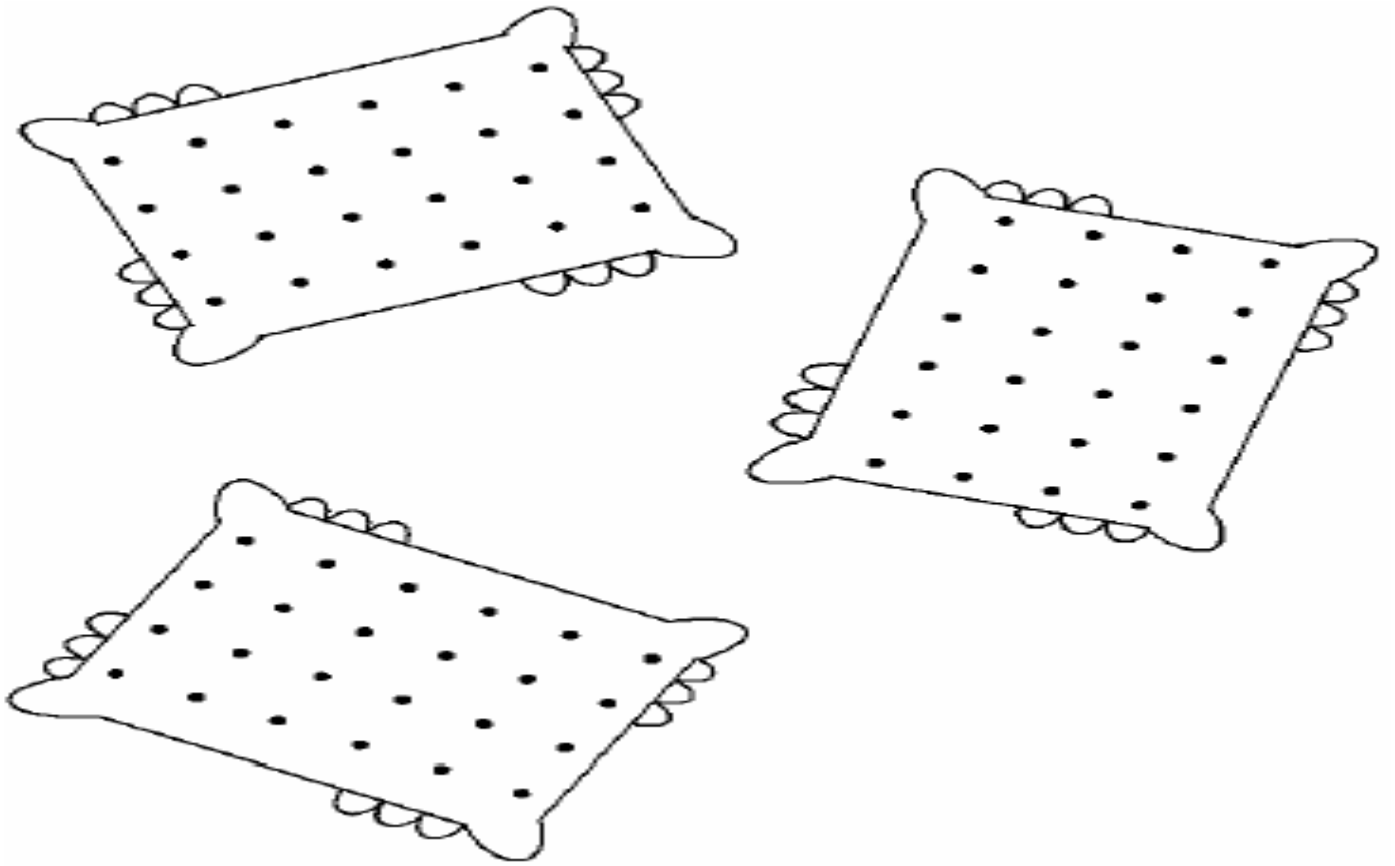

Associe suivant la couleur.



Colorie en vert l'élément le plus grand, en bleu l'élément le plus petit.

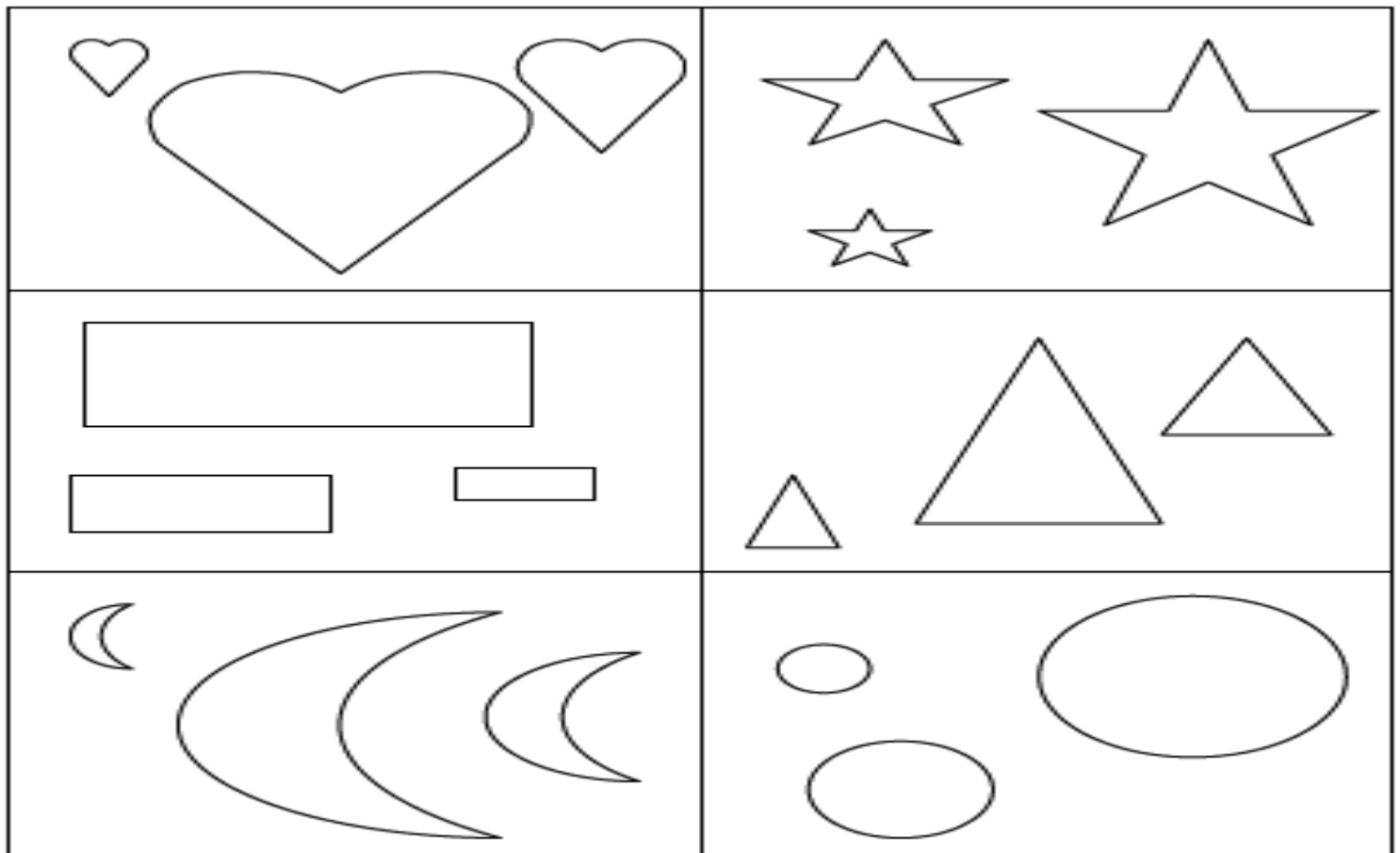

Complète le dessin en suivant les pointillés.

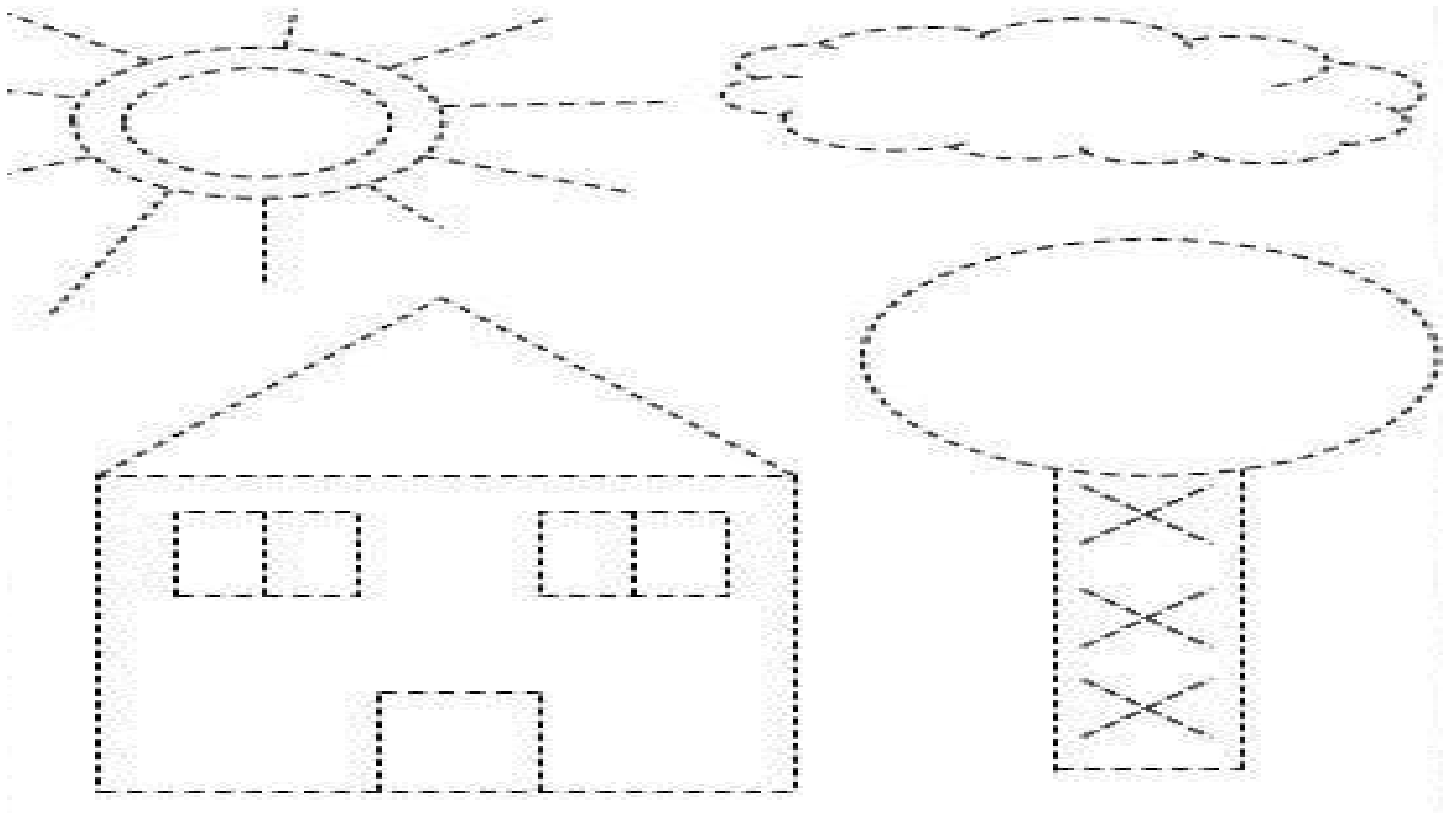

Observe et relie.

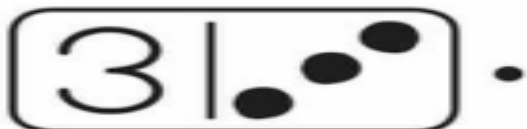

Essaie d'écriture les chiffres.

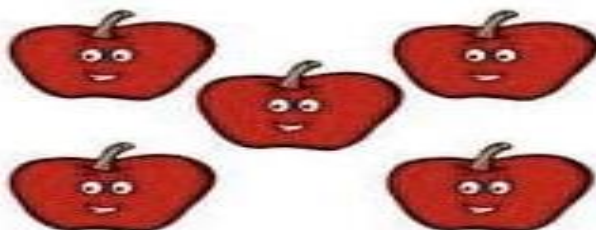
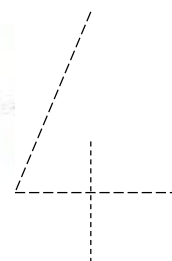
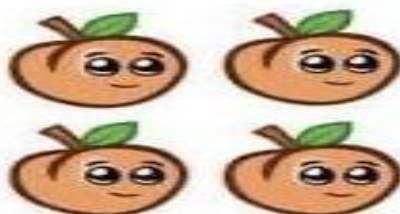
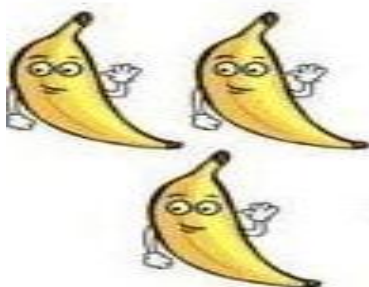



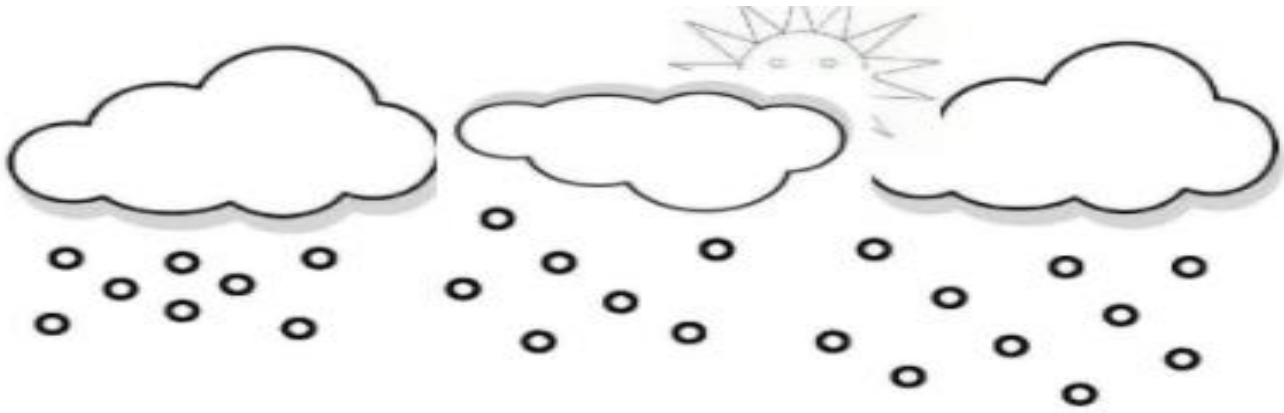



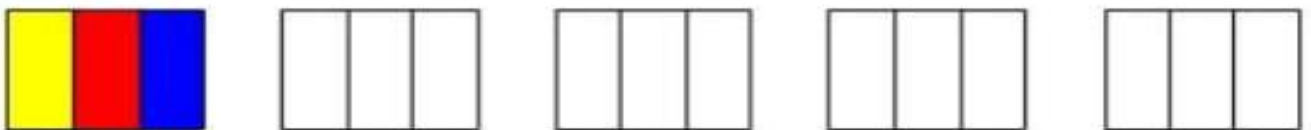























Dessine la neige.



Colorie en respectant le code.



Colorie autant de ballons que l'indique le chiffre.

2						
5						
4						
3						
1						

Colorie en fonction du code.

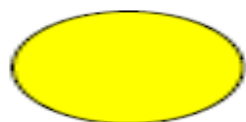

JAUNE



ROUGE



VERT



BLEU

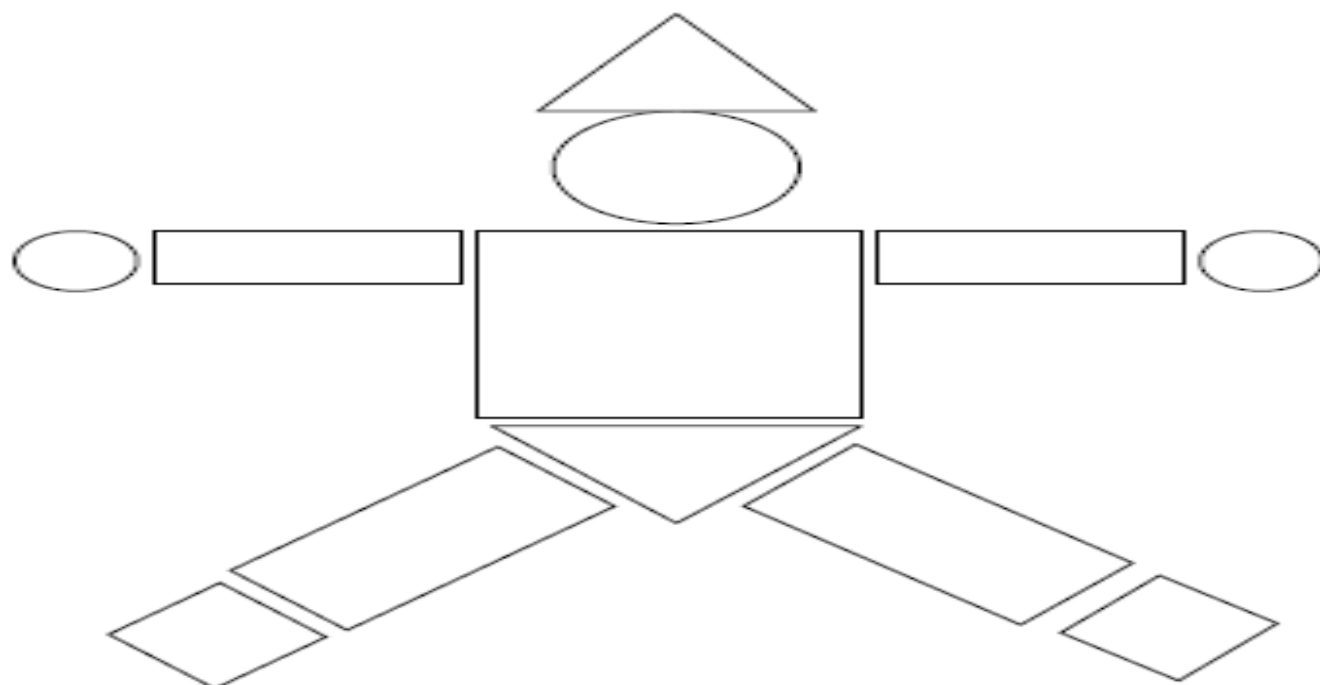

Passes sur les traits avec ton feutre.

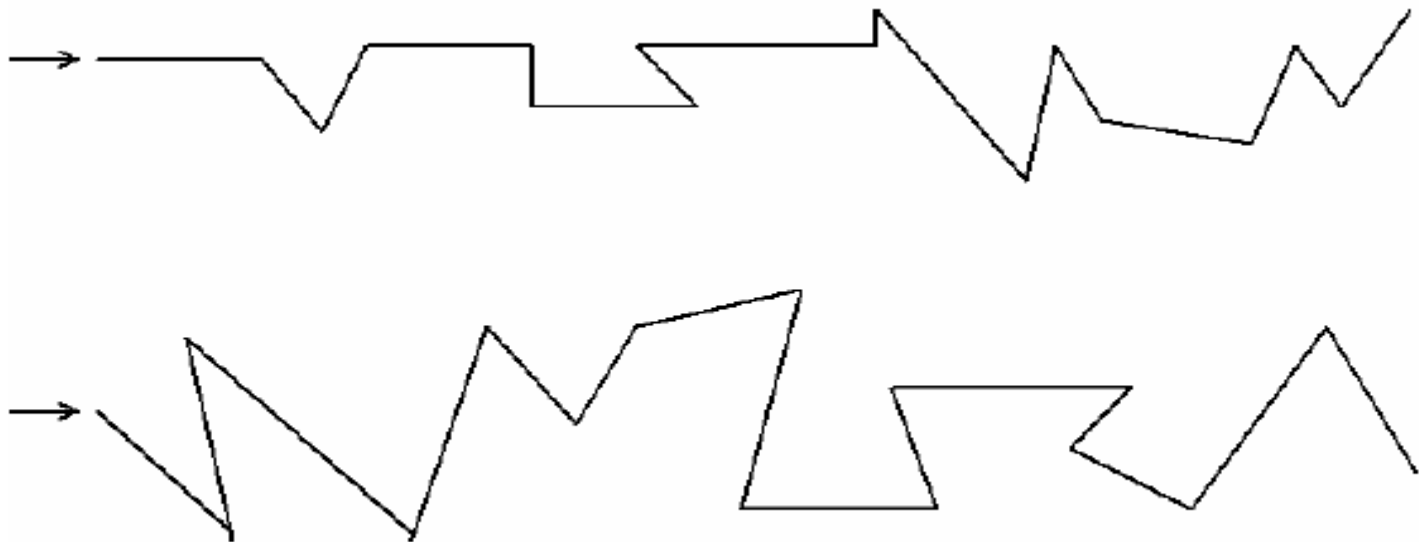

Entoure les lapins. Ne touche pas aux autres animaux.

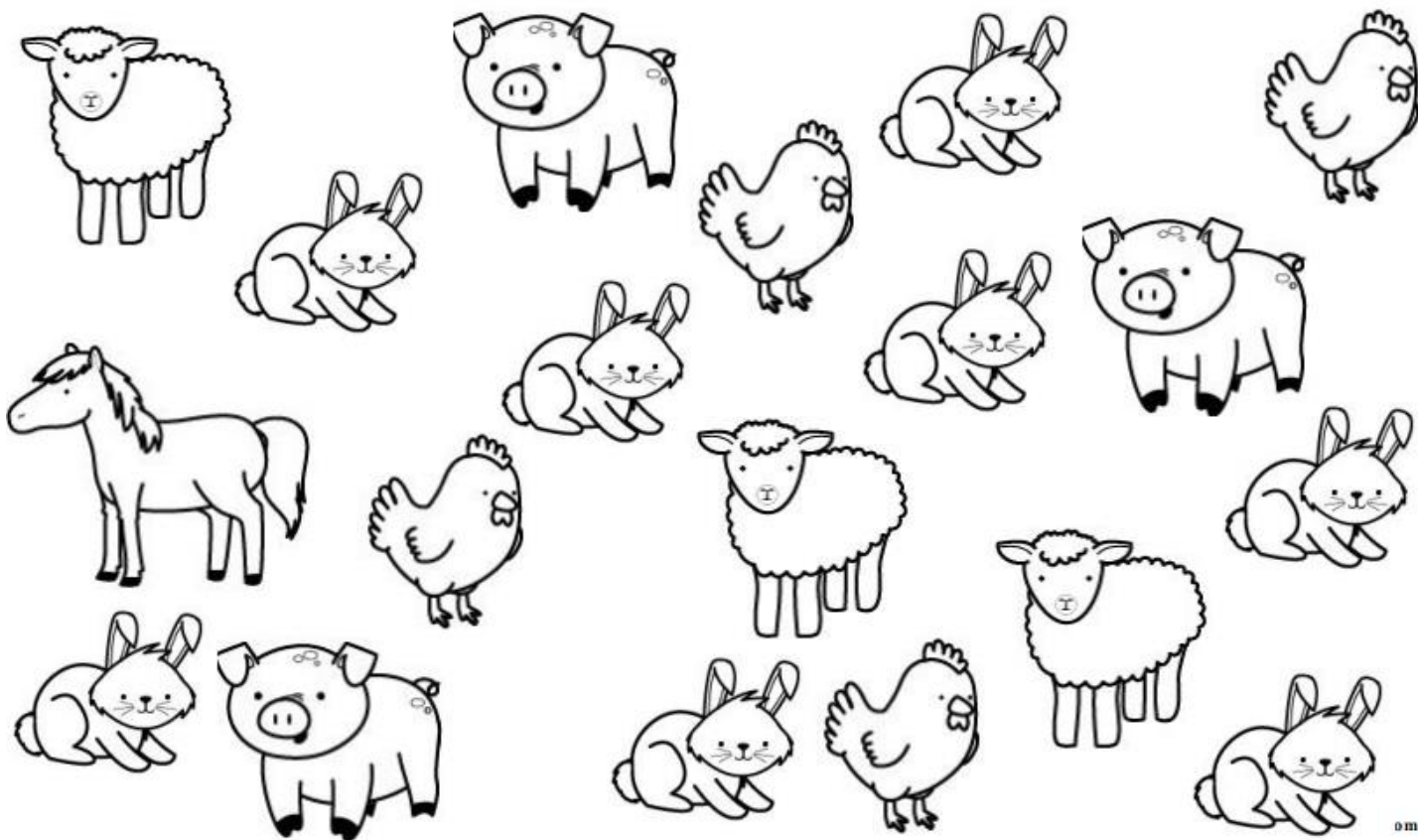

Quelques activités renforçant la motricité fine



C'est la gym des doigts !

	<p><i>Le parcours motricité fine de Hop'Toys</i></p> <ul style="list-style-type: none">- L'enfant doit suivre les lignes tantôt droites, tantôt courbes, en pointillés ...avec son doigt. Et réaliser les gestes demandés : taper dans les mains, faire des gestes avec les doigts...
	<p><i>Le tri</i></p> <ul style="list-style-type: none">- Coordination œil-main.- Pour ce faire, il suffit de mettre plein de petits objets à la disposition de l'enfant. Puis, lui demander de les séparer, trier et classer selon leur forme, taille ou couleur.
	<ul style="list-style-type: none">- Précision et coordination œil-main.- Des cailloux, des boutons ou encore des perles ou des macaronis à aligner en suivant le dessin.
	<p>La pâte à modeler est géniale pour travailler les petits muscles des doigts. Pétrir, rouler, étaler la pâte aide beaucoup à muscler et préparer l'écriture</p>
	<p><i>Les petites galettes</i></p> <ul style="list-style-type: none">- L'enfant dépose six petites boules de pâte à modeler sur le rebord d'une table. Il doit presser chaque boule en utilisant un doigt différent.- L'enfant peut débuter l'activité avec les pouces seulement et ensuite poursuivre avec tous les doigts.



Le combat d'anneaux

- Cette activité en duo consiste à joindre le pouce et l'index pour former un anneau en s'accrochant à l'anneau d'un autre joueur. Il faut tirer vers soi de toutes ses forces. Le gagnant est le joueur qui a réussi à garder son anneau fermé.

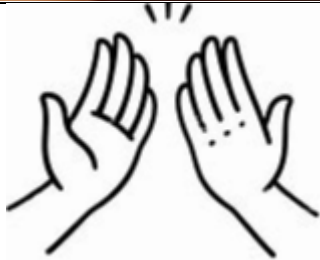

- L'enfant joint ses 2 mains ensemble, puis tape ses 2 pouces ensemble. Il arrête et continue avec ses 2 index. Il continue avec ses 2 majeurs, etc.
- Quand il finit, il recommence avec les auriculaires dans l'autre sens.



Monsieur le pouce

- Chaque doigt touche le pouce à tour de rôle: l'index, le majeur, l'annulaire, puis l'auriculaire. On répète 5 fois à l'aide d'une seule main. Ensuite, on fait les deux mains en même temps.
- Pour finir, on met les mains derrière la tête pour faire ce même mouvement, sans regarder!





- Demander à l'enfant d'imiter. Varier les gestes.



- Pincer et tenir minutieusement.

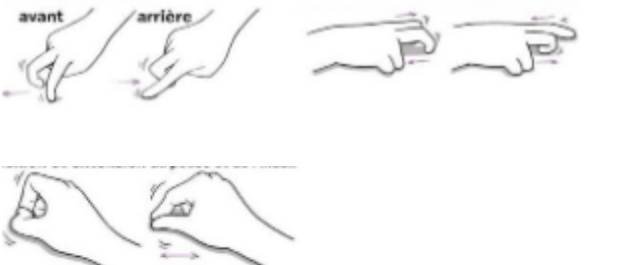

- Enfiler des perles ou des boutons.

	<ul style="list-style-type: none"> - <i>La marche avant et arrière.</i> - <i>Gratte-gratte.</i> - <i>Picotti-picotta</i> : flexion et extension de trois doigts rassemblés comme le bec d'une poule (le pouce, l'index et le majeur).
	<ul style="list-style-type: none"> - Froisser entre les doigts des bouts de crépon ou de papier. - Coller pour réaliser un dessin ou décorer l'initiale de son prénom.
<ul style="list-style-type: none"> ▪ Éplucher des fruits, ▪ Casser des coques de fruits à coque (noix, noisettes...), ▪ Pétrir de la pâte, ▪ Couper des légumes, ▪ S'habiller (fermer les boutons ou la ceinture), ▪ Jardiner, bricoler (visser, dévisser, appuyer, ouvrir des serrures ou des cadenas...), ▪ Faire le ménage (notamment la manipulation des éponges), ▪ Jouer librement avec de l'eau, de la terre, de la pâte à modeler... 	<p>Saisissez les occasions du quotidien !</p>

Et enfin...

Des liens et des applications utiles

Des chansons et des comptines	<ul style="list-style-type: none">- Les chiffres : https://youtu.be/gXcPyVN_D5g- Les couleurs : https://youtu.be/yJiU4htXzh8- La chanson de l'alphabet : https://youtu.be/5xuZxGirWQI- Comptines à gestes : https://youtu.be/8J68OPnGd4Q- Les formes : https://youtu.be/xEfJklQAyp4
Des activités de motricité fine	<ul style="list-style-type: none">- https://youtu.be/hm1_RP-DiCY- https://youtu.be/DVxPB-2h5e0- https://youtu.be/VjAPb7o-pbw
Des applications à télécharger sur téléphone portable (Adapter les paramètres « settings » pour le niveau et la langue « Français »)	<ul style="list-style-type: none">- Alchabet  - Learn French - Alphabet 